



EASY TO
ASSEMBLE



INTELLIGENT



VERSATILE



Ditec Olly C

EN

Automation for interior sliding doors
Freedom in every movement

Ditec Olly C



Small in size, big in performance

Designed with space-saving in mind, the automation system can be installed on commercially available runners for recessed panels.

For every need

The automation system is available in three versions: with infra-red radar for automatic operation and/or with pushbutton panel and/or remote control.

Two practical mounting sets

The automation system is supplied complete with two separate sets to make up 1-wing (up to 1000 mm) or 2-wing (up to 2000 mm) sliding doors. The sets consist of:

- an actuator complete with control panel
- transfer unit
- transmission belt
- belt mountings
- fastening brackets
- support profile and closing cover.

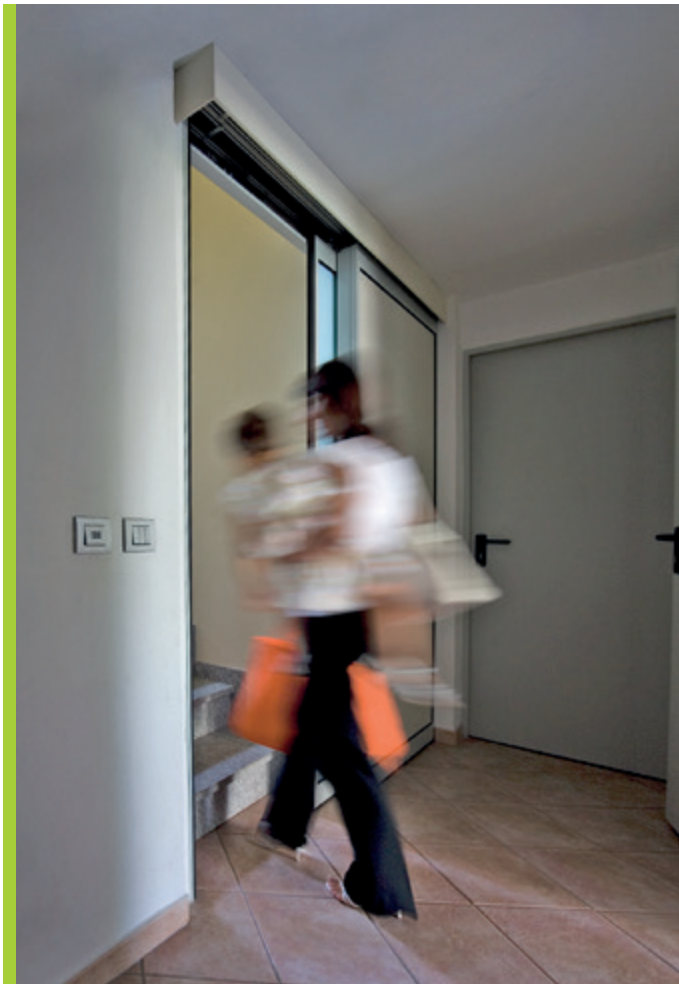

OUR EXPERIENCE AT YOUR SERVICE

A complete range. A team of specialists in the sector. Excellence in technologies and design. Passionate to be different. Entrematic is a commercial partner with a complete range of products for the automation of entrances, which combines specialised know-how and very famous brands. The Ditec brand has been a world leader for more than forty years, offering a complete range of automation systems for gates, automatic doors and high-speed doors.

Normstahl
ENTRE/MATIC

DYNACO
ENTRE/MATIC

NERGECO
ENTRE/MATIC

Ditec
ENTRE/MATIC

em
ENTRE/MATIC

Amarr
ENTRE/MATIC

KELLEY
ENTRE/MATIC

SERCO
ENTRE/MATIC

Versatile and quiet



EASY TO ASSEMBLE

- Basic and intuitive with just a few screws to put it together
- PLUG&PLAY automation system



INTELLIGENT

- Compatible with all commercially available guides for hideaway doors
- Compact, light and silent



VERSATILE

- Multiple functions such as PUSH&GO, activated via sensors and controlled remotely via radio
- Wide range of accessories to adapt to any requirements



SECTIONS

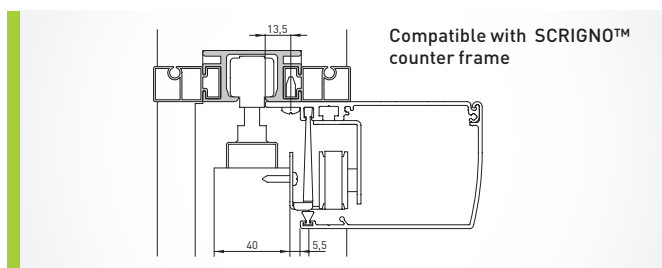
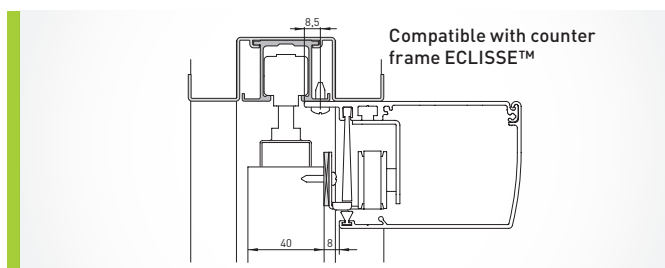

INSTALLATIONS

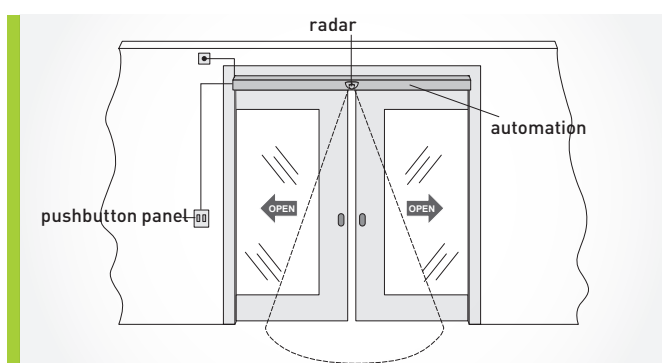
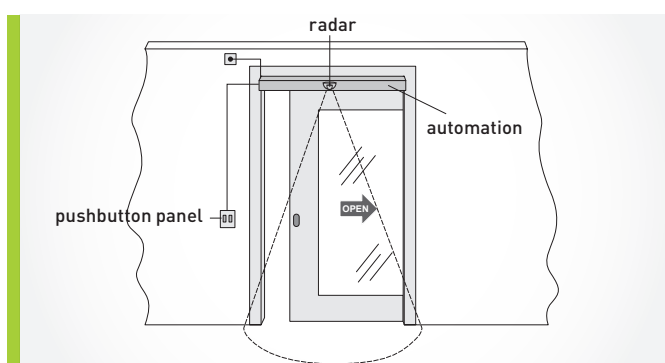

THE RIGHT ACCESSORIES ARE EASY TO CHOOSE

PID24

Proximity sensor



OCL

Radio receiver kit complete with wiring and transmitter



PFP1

Rectangular elbow pushbutton



PFP2

Stainless steel rectangular elbow pushbutton



Technical specifications of available models and main functions of the system

	OLLY C		EL06A
Description	electromechanical actuator for interior sliding doors	Description	control panel for 1 motor 24 V DC
Special uses	disabled use	Mains power supply	230 V AC / 50-60 Hz
Stroke control	encoder	Energy saving 	energy saving when in stand-by and during use
Maximum capacity	40 kg (1 wing) 55 kg (2 wings)	Number of motors	1
Service class	3 - frequent	Motor power supply	24 V DC / 1.8 A
Power supply	230 V AC / 50-60 Hz	Accessories power supply	24 V DC / 0.3 A
Power input	0.2 A	Electrolock	24 V DC / 0.5 A
Torque / Thrust	30 N	Kinematic management with Encoder	■
Opening speed	0.4 m/s	Obstacle detection (causes stop when opening or reverse when closing)	■
Closing speed	0.2 m/s	Push opening (PUSH&GO)	■
Maximum opening width	2 m	Push closing (PUSH&GO)	■
Anti-panic system	OC LOKA	Independent open control	■
Operating temperature	-20°C / +55°C	Independent close control	■
Protection rating	IP 20	Timer-controlled automatic closing	0 - 30 s
Product dimensions mm (H x D x L)	67 x 114 x 1000	Monitored emergency reverse	■
Control panel	EL06A (built-in)		

When building the system, only use Ditec accessories and safety devices.

Every Ditec automation features CE marking and is designed and built in compliance with the safety requirements of the Machinery Directive (2006/42/EC), of the Electromagnetic Compatibility Directive (2014/30/EU) and of the Low Voltage Directive (2014/35/EU) and of other Directives, laws, specific standards for special products and situations.

The Company reserves the right to make changes which may improve the products.

For this reason, the technical details given are not binding.

Pictures were taken with the consent of those concerned or in public locations.

Further information can be found in the Technical Manuals available at the website: www.ditecentrematic.com

ENTREMATIC



Entrematic Italy S.p.A.

Largo U. Boccioni, 1 • 21040 Origgio (VA) • Italy

Tel +39 02 963911 • Fax: +39 02 9650314

ditec@entrematic.com

www.ditecentrematic.com • www.entrematic.com

Cod. P223B - 02/2018

Ditec Ollly C

gdp milano 177765

Present in: France, Germany, Spain, Turkey and Canada.

For addresses and contact information see our website www.ditecentrematic.com

